

AEROCRANE

BUILD MANUAL

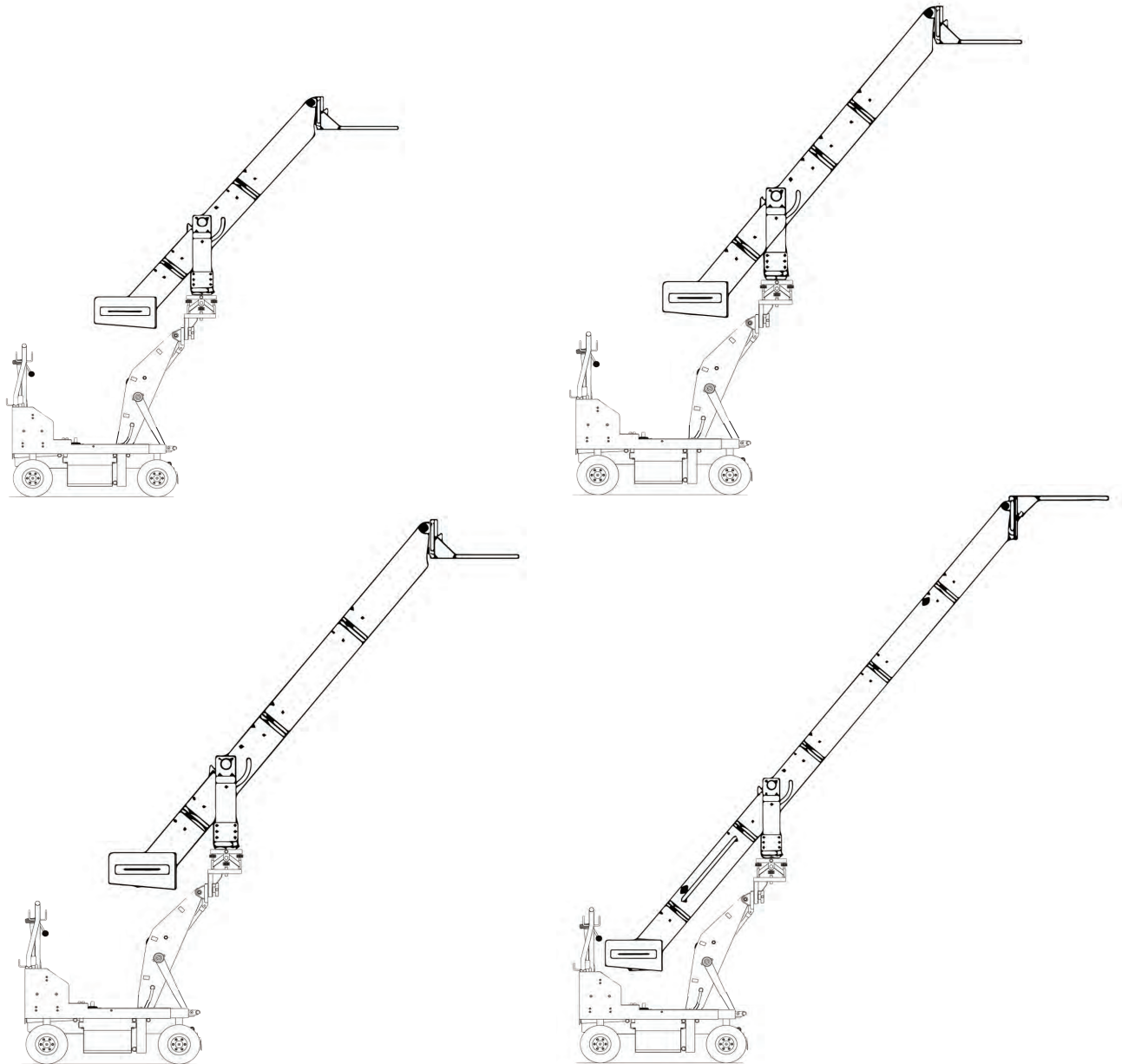

ATLAS LIGHTING LLC

AEROCRANE ROLLING CASE

- [1] Center Crane Section with w/ Mitchell Adapter
- [1] Front Arm Section w/ 2' Rod
- [1] Rear Arm Section w/ 1' Rod
- [2] 2' Section w/ 2' Rod
- [1] 2' Section w/ 2' Rod and side handles
- Weight Bucket
- Mitchell Spoonbill
- 150/100mm Ball Head Adapter and Washer
- Euro 4-Way Leveling Head
- [1] - Euro Low Mode Bracket

- **WEIGHT CART**
- [4] 15lb Weights
- [7] 25lb Weights

EXTRAS

- **AKS DRAWER**
- [2] Swiss-Made Punches
- Fixed Spanner Wrench
- Face Spanner Wrench
- Torpedo Level
- Euro - Riser
- 9pc Metric Allen Key Set
- [2] Outrigger Arms
- Outrigger Cable Pouch
 - [2] Outrigger Cables
- [1] Sliding Weight
- Manual

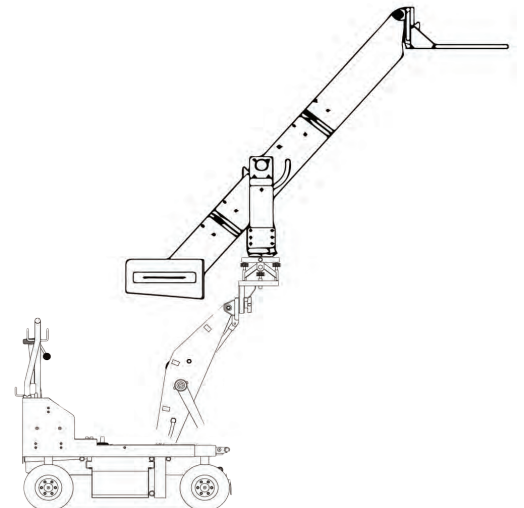

AEROCRANE

CASE LAYOUT

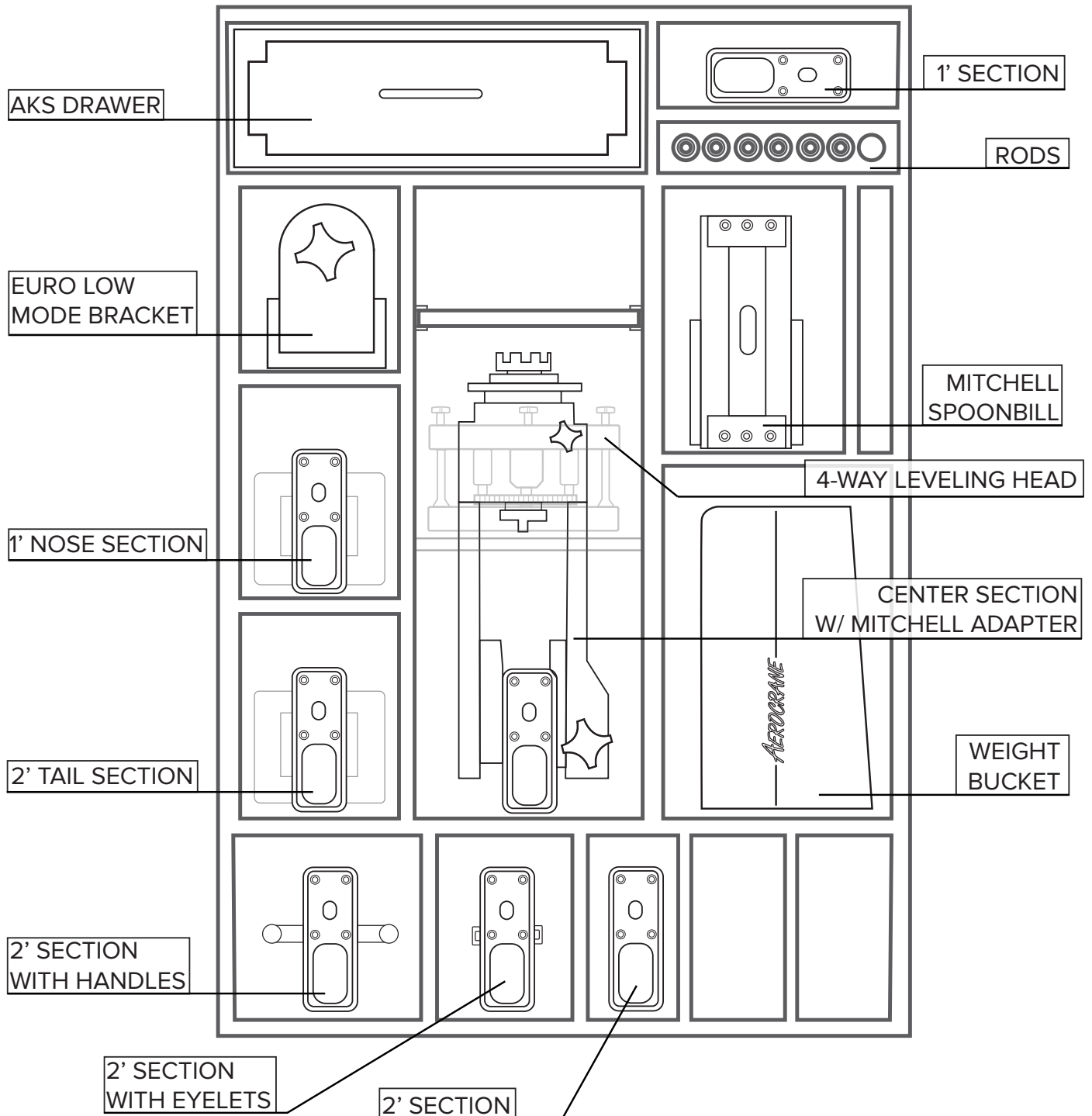

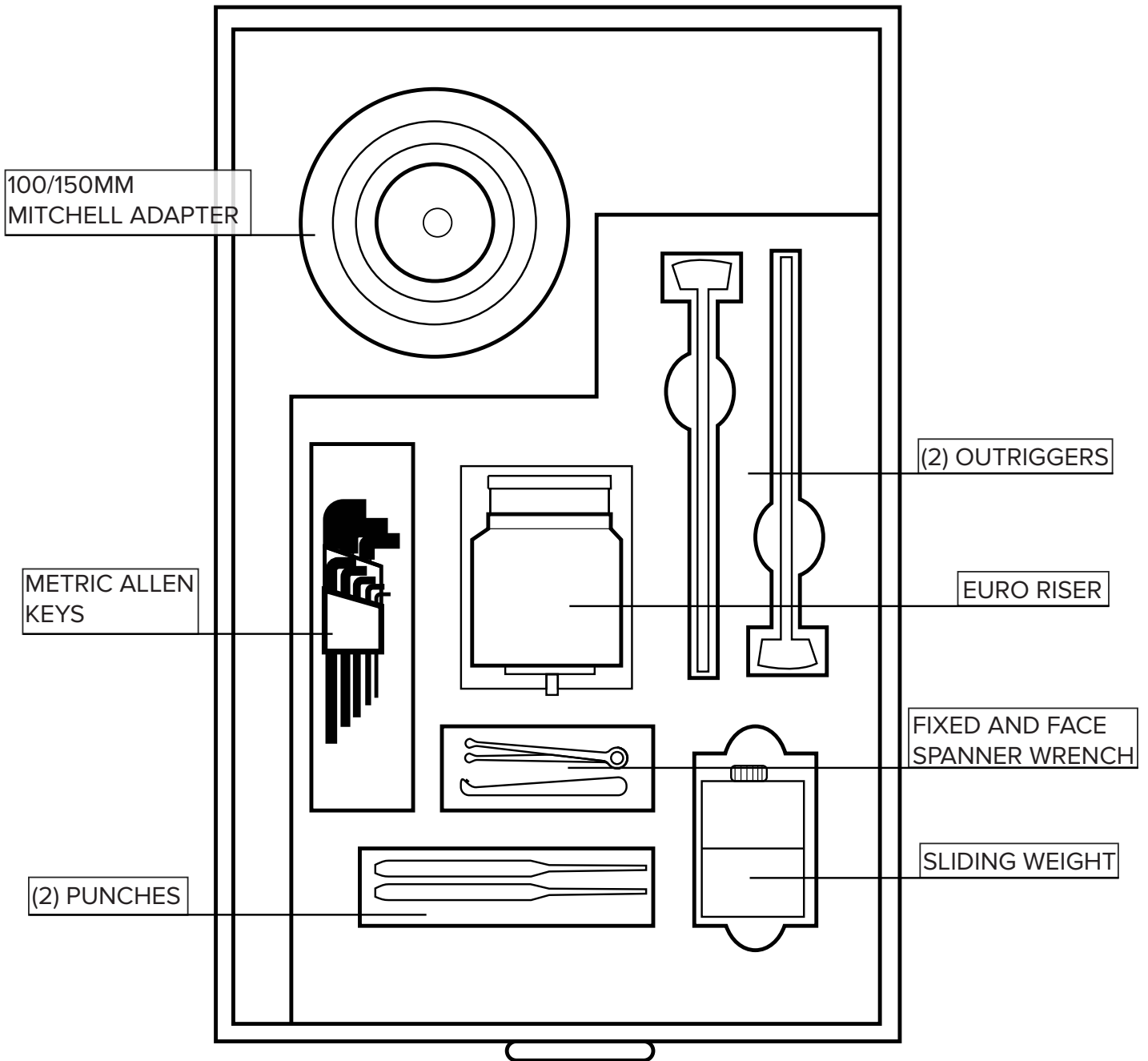

AEROCRANE

VERSION 1

ARM REACH	4' 8"
OVERALL LENGTH	7' 3"
MAX HEIGHT	5' 8" *From ground to Mitchell Mount with a 2'4" platform*
MINIMUM HEIGHT	1' 1" *From ground to Mitchell Mount with a 2'4" platform*
MAX PAYLOAD	90lbs *Weight Limit of the Mitchell Spoonbill*
CRANE WEIGHT	88.4lbs *Without counter weight*

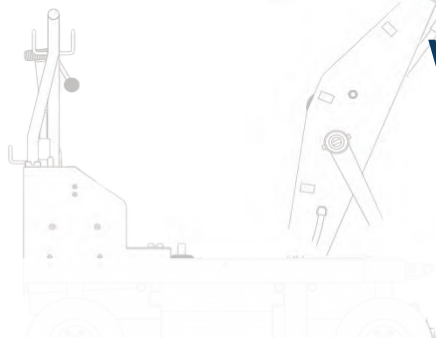
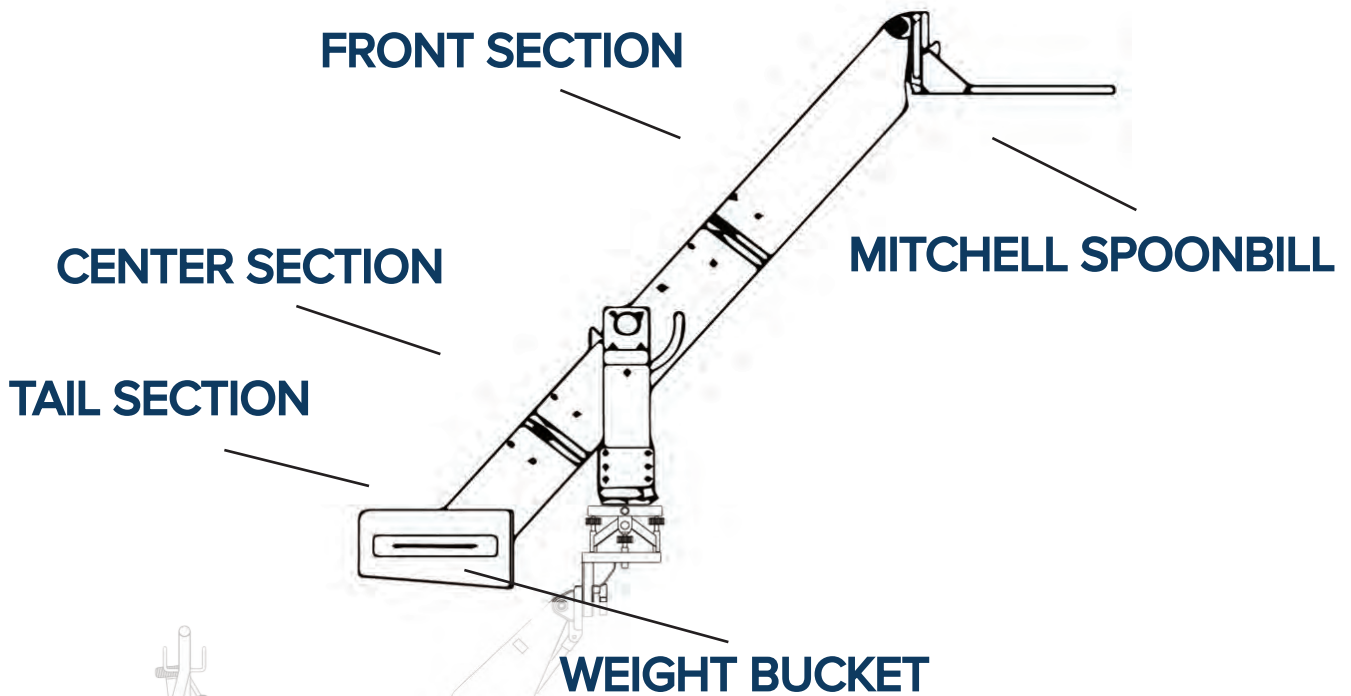

AEROCRANE

VERSION 2

ARM REACH	5' 8"
OVERALL LENGTH	8' 6"
MAX HEIGHT	6' 6" <i>*From ground to Mitchell mount with a 2'4" platform*</i>
MINIMUM HEIGHT	4" <i>*From ground to Mitchell mount with a 2'4" platform*</i>
MAX PAYLOAD	90lbs <i>*Weight Limit of the Mitchell Spoonbill*</i>
CRANE WEIGHT	95.2lbs <i>*Without counter weight*</i>

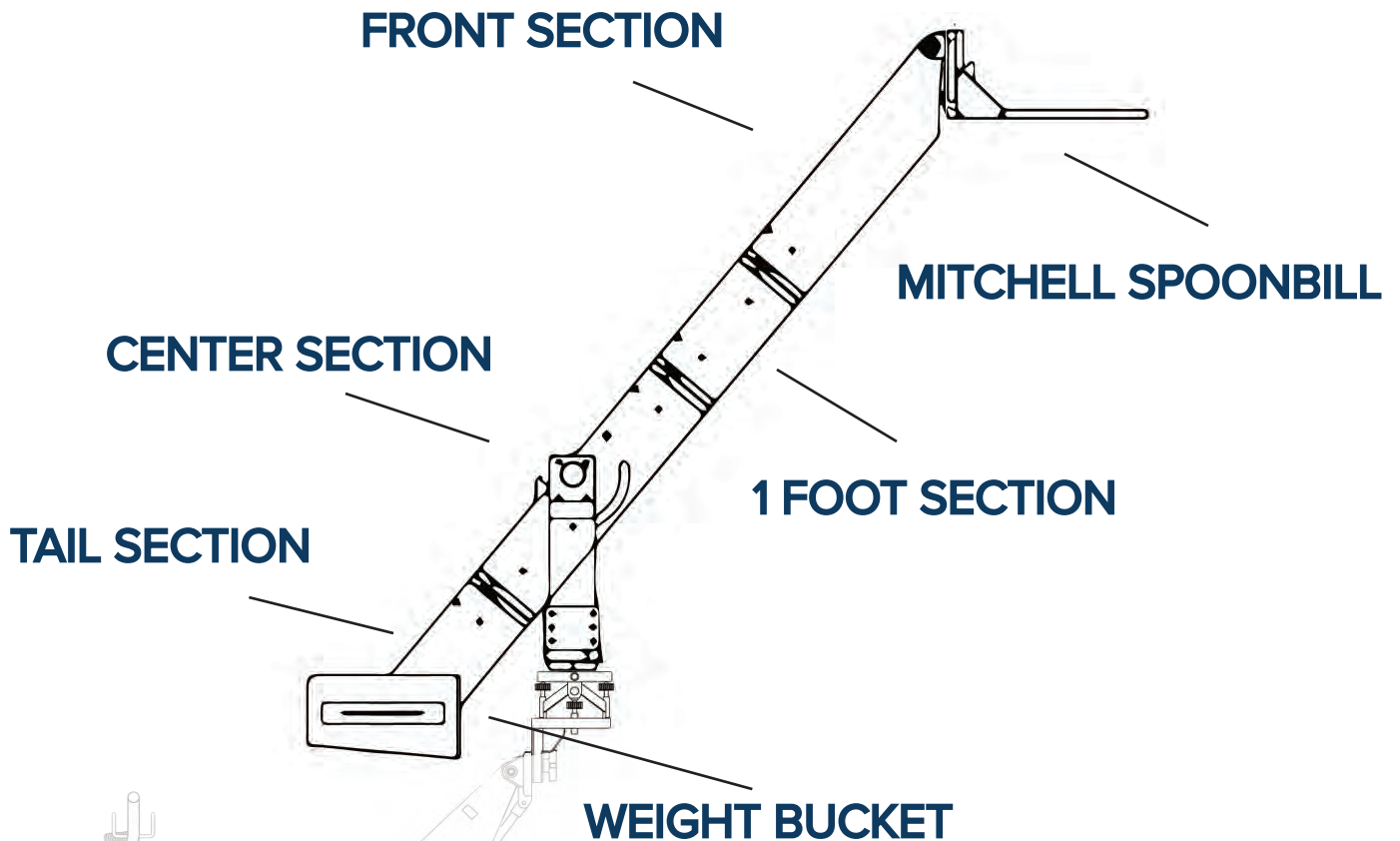

AEROCRANE

VERSION 3

ARM REACH	6' 8"
OVERALL LENGTH	9' 6"
MAX HEIGHT	8' 5" * *From ground to Mitchell Mount with a 2'4" platform*
MINIMUM HEIGHT	-1' 3" * *From ground to Mitchell Mount with a 2'4" platform*
MAX PAYLOAD	90lb *Weight Limit of the Mitchell Spoonbill*
CRANE WEIGHT	99.4lbs *Without counter weight*

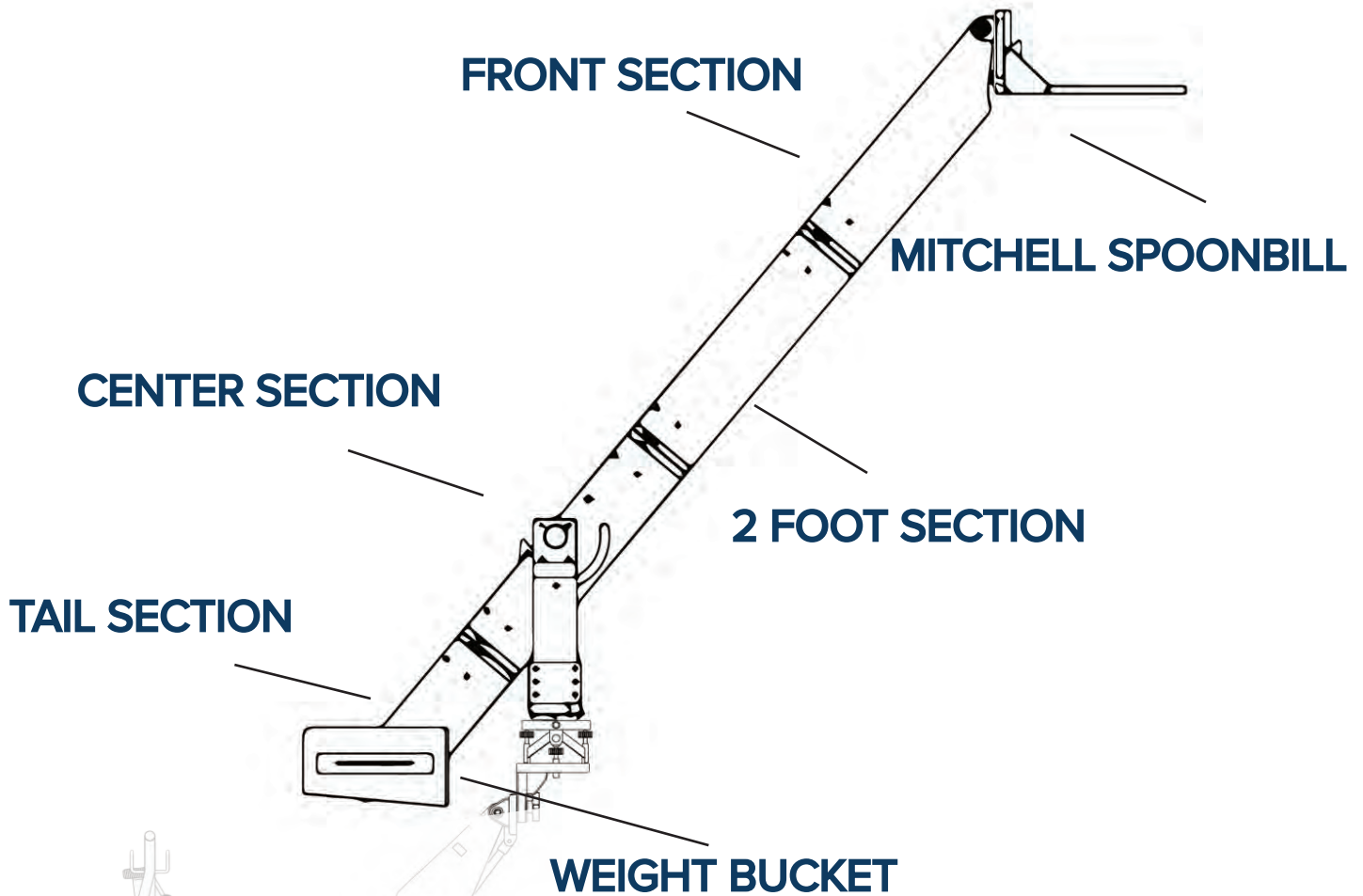

AEROCRANE

VERSION 4

ARM REACH	9'
OVERALL LENGTH	13'
MAX HEIGHT	9' * *From ground to Mitchell Mount with a 2'4" platform*
MINIMUM HEIGHT	-2' 2" * *From ground to Mitchell Mount with a 2'4" platform*
MAX PAYLOAD	90lb *Weight Limit of the Mitchell Spoonbill*
CRANE WEIGHT	113.2lbs *Without counter weight*

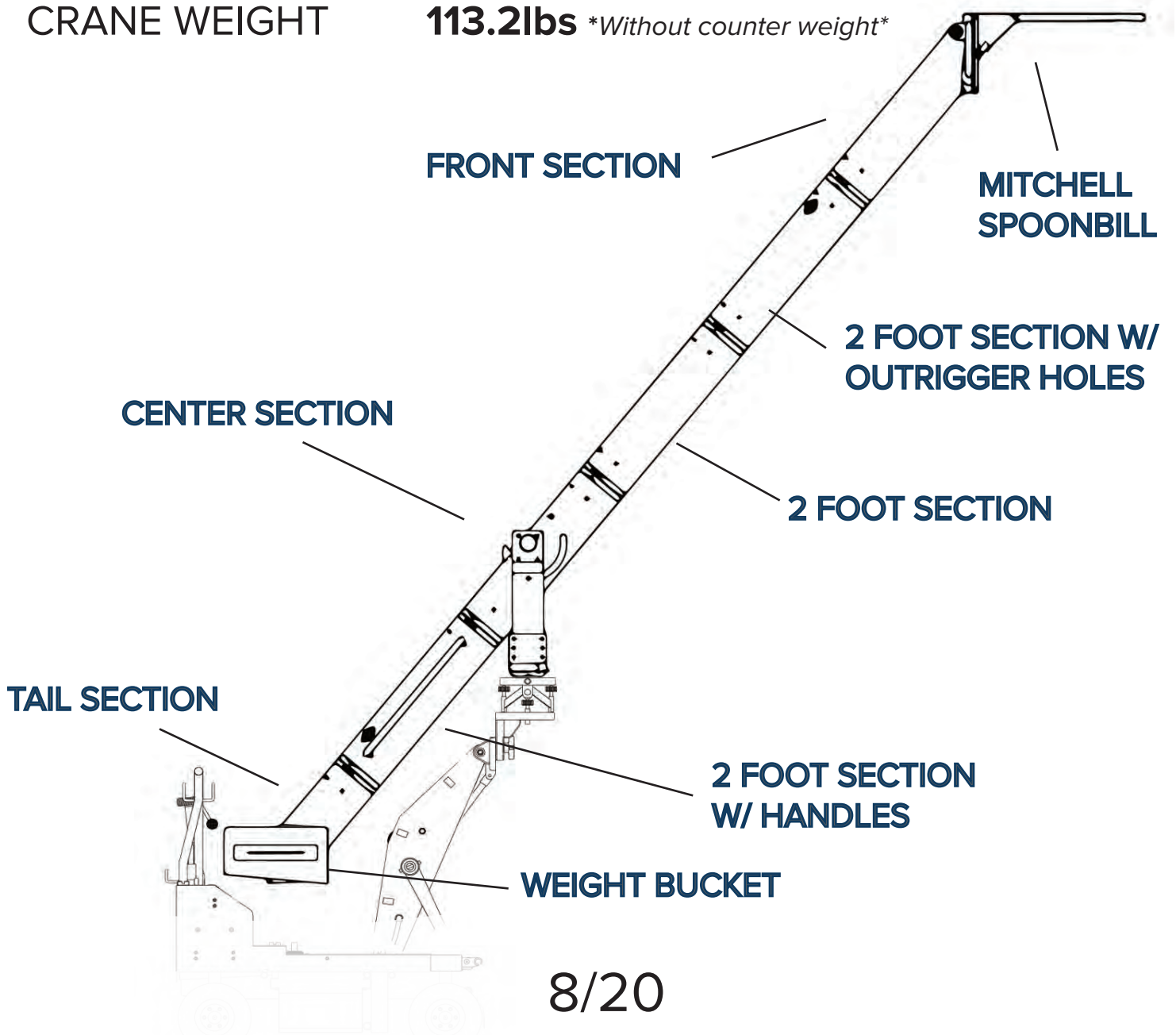

AEROCRANE

VERSION 5

ARM REACH	10'
OVERALL LENGTH	14.5'
MAX HEIGHT	9.5' * *From ground to Mitchell Mount with a 2'4" platform*
MINIMUM HEIGHT	-2' 9" * *From ground to Mitchell Mount with a 2'4" platform*
MAX PAYLOAD	90lb * *Weight Limit of the Mitchell Spoonbill*
CRANE WEIGHT	140.2lbs * *Without counter weight*

